

The Rear Wheel

1. Start Pro/Desktop and begin a new design by clicking on the icon or going to File > New > Design.
2. Right click on the Lateral Workplane, and start a new sketch. Name it wheel, hold down shift + W.
3. Draw a circle with a diameter of 1.625 inches. (Be sure you are in inches!!)

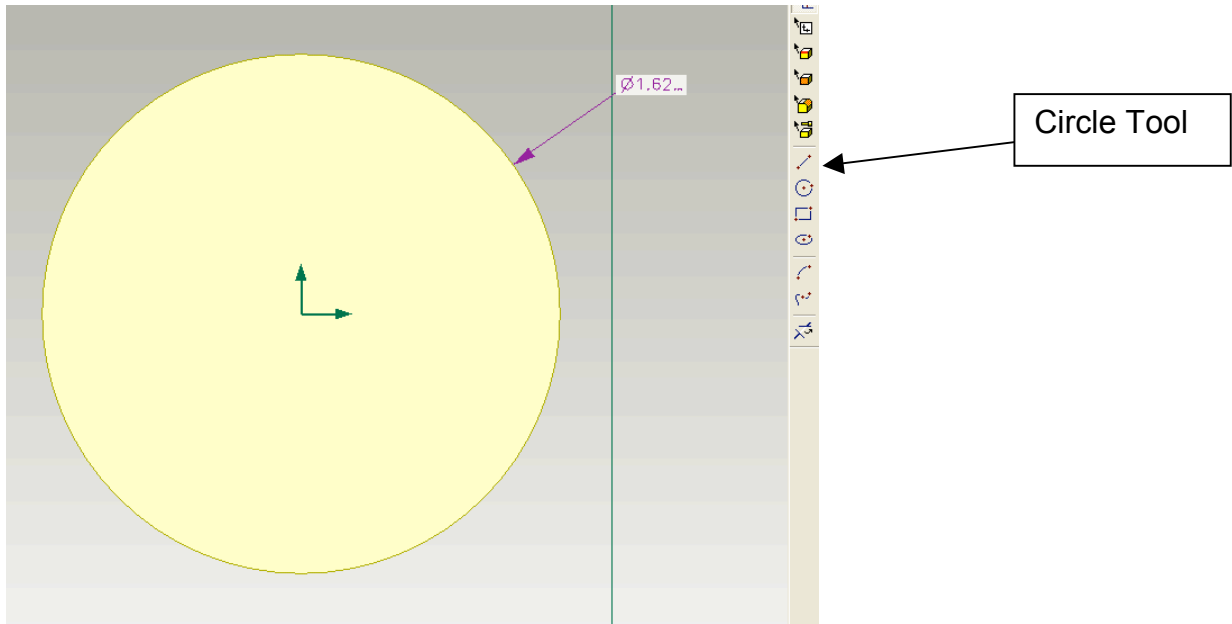

4. Use the **Line Select** Tool to pick the outer edge of the circle so it turns red. Then **Extrude** the circle, adding material, .75 inches, above the workplane.

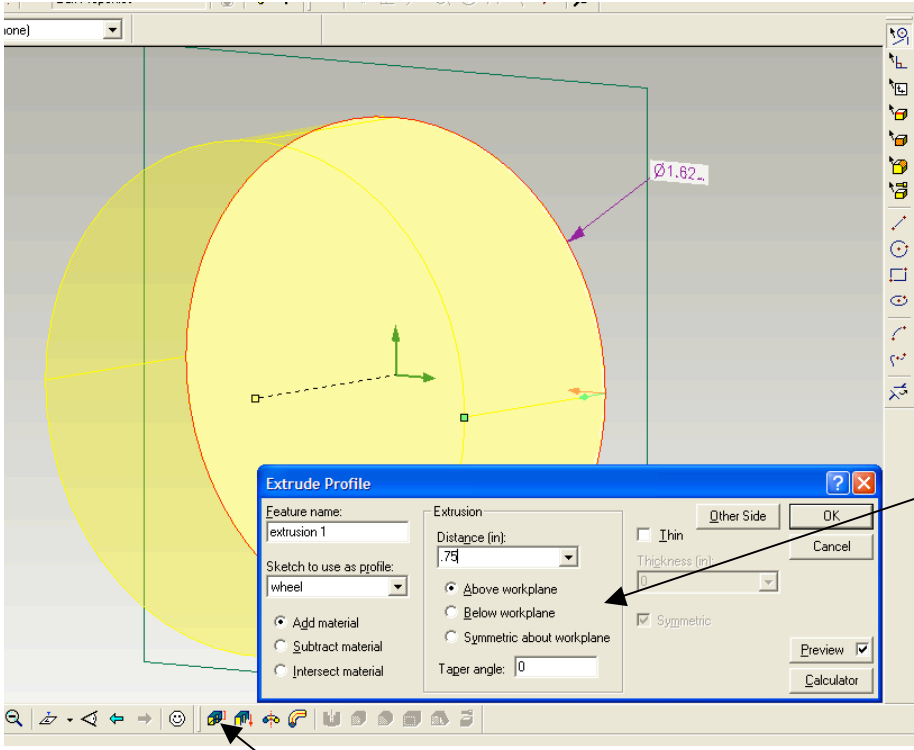

Make sure dialog box matches these selections.

Extrude

5. Now use the Select Faces tool to choose the newly created outside face of the wheel, it will turn red.

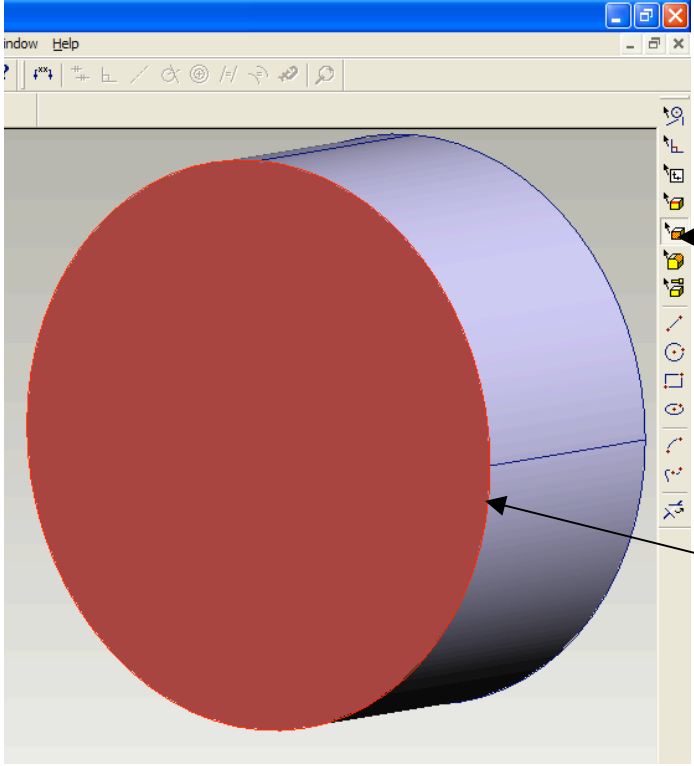

Select Faces Tool

Click on the outside face of the wheel, turn the picture to get a better view.

6. Now go to the top of the screen to the **Workplane** menu and select **New Workplane**. When the dialog box appears, choose **offset** and give it a distance of **-.5** inches.

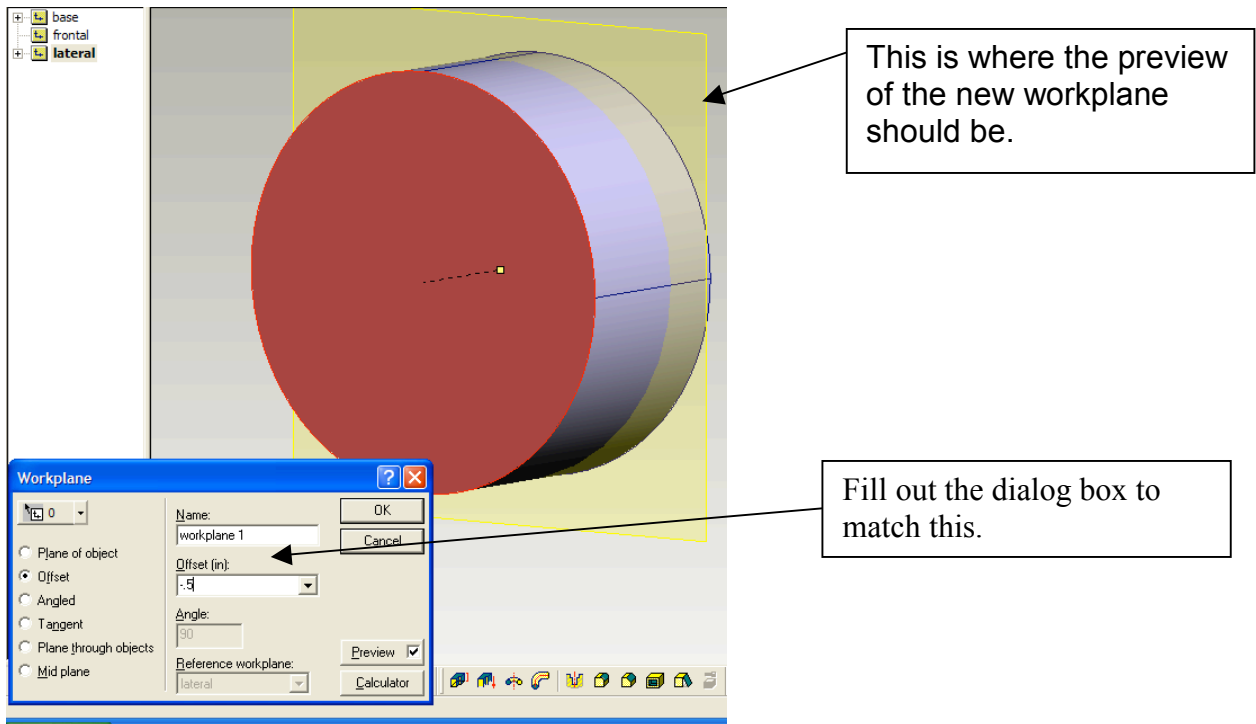

7. A new workplane will appear on the left hand side of the screen underneath the Lateral. Right click on this **new workplane 1**, create a **new sketch** and call it **rim**. Hit **Shift + W**.

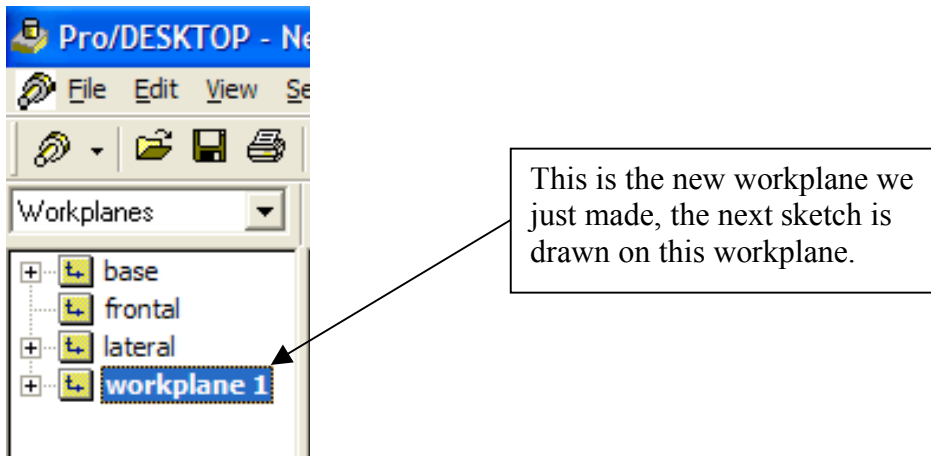

8. Draw a circle that is 1 inch in diameter, use line select to choose the edge of the circle, and use the project command.

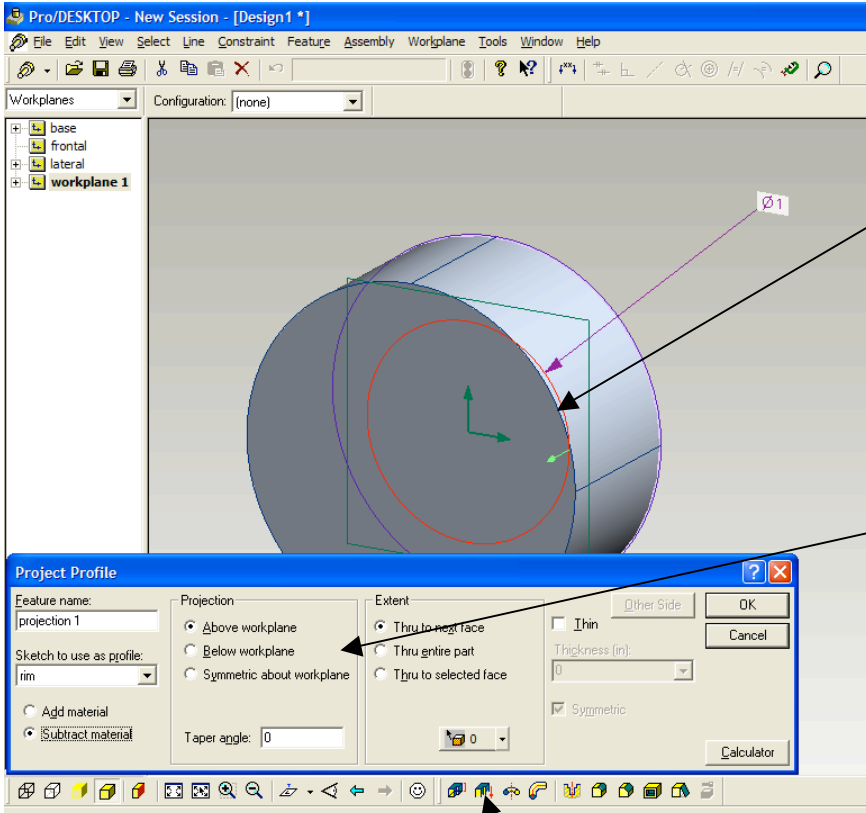

Use Select Lines tool to choose the circle you just made.

Make sure dialog box is filled out like this to create the "rim".

Project Profile

When you're done, this is what you should have:

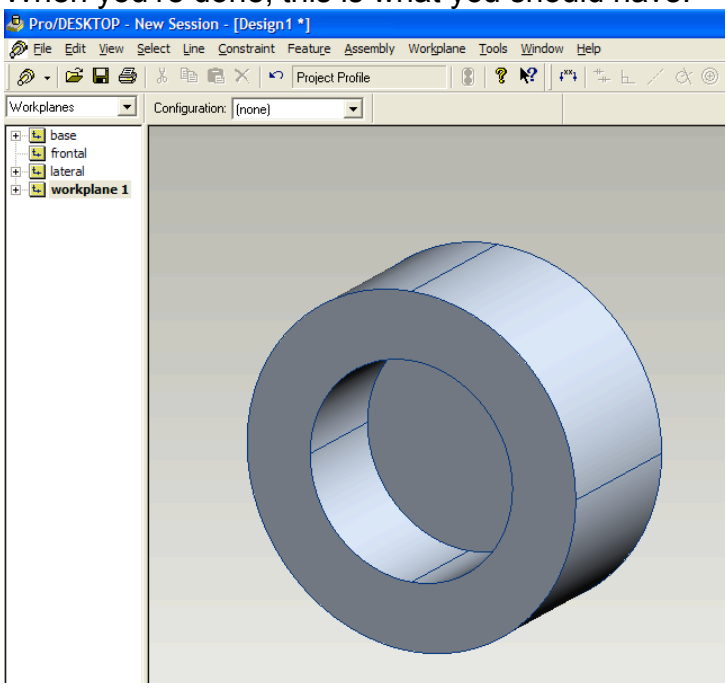

9. To create the hub, right click on the **Lateral** workplane to create a **new sketch**, name it the **hub**. Hit **Shift + W** to center the drawing.

10. Draw a circle on the lateral workplane that is .25 inches in diameter.

9. Make sure your drawing in the lateral workplane.

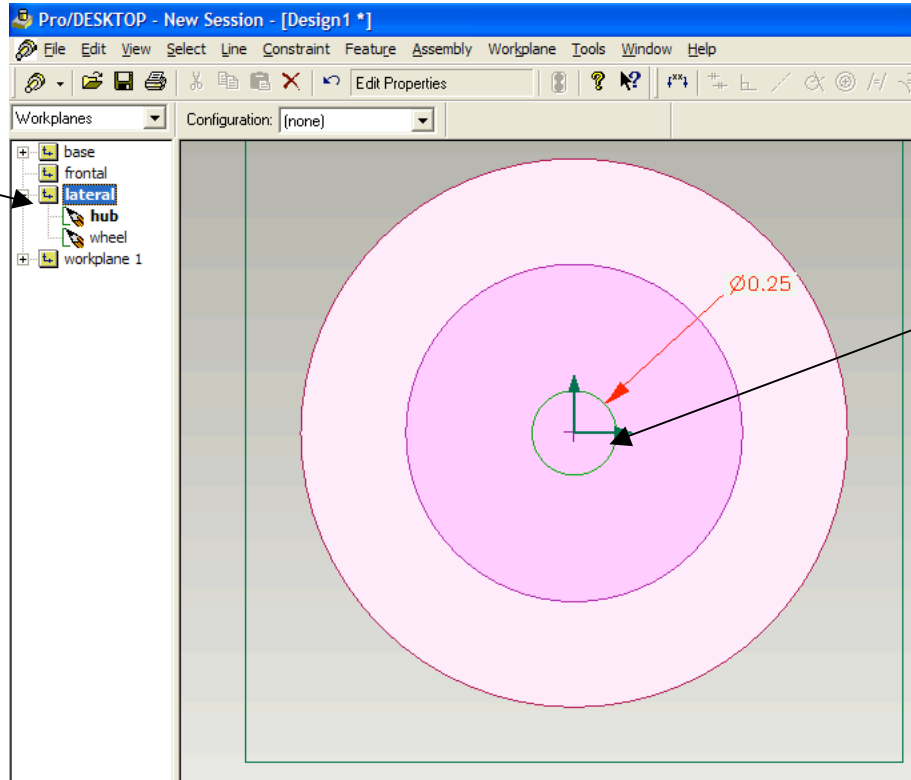

10. Draw a circle here .25 in diameter, this is the hub.

11. Use the select lines tool to choose the outside edge of the circle you just drew. Extrude the circle above the workplane .45 inches.

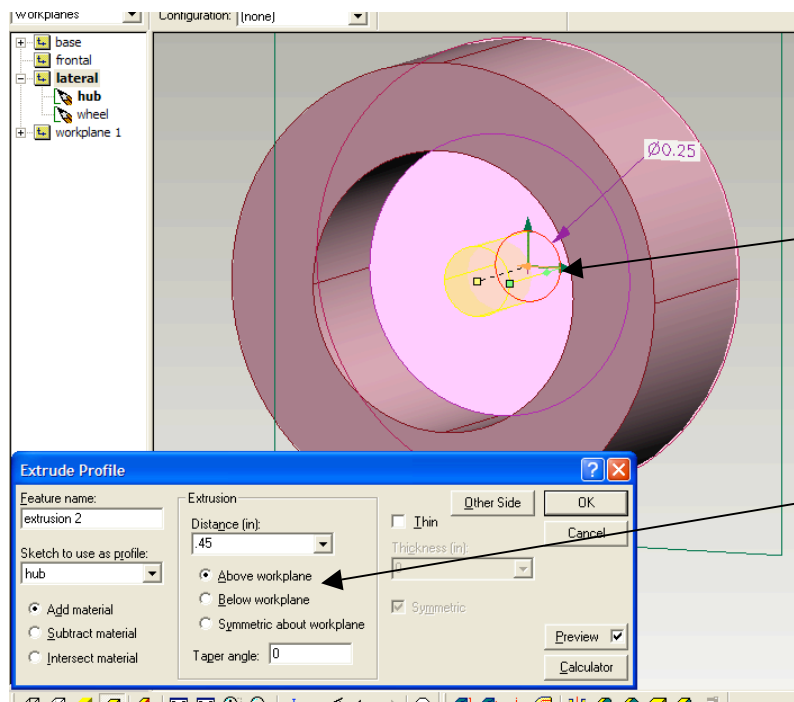

Extrude this circle.

Fill out dialog box with these options.

11. Finally its time to put the hole in the back of the wheel. Again, right click on the **Lateral Workplane** and create a **new sketch** called the **hub hole**.

12. Draw a circle, in the center of all the other circles drawn before, with a diameter if **.125 inches**.

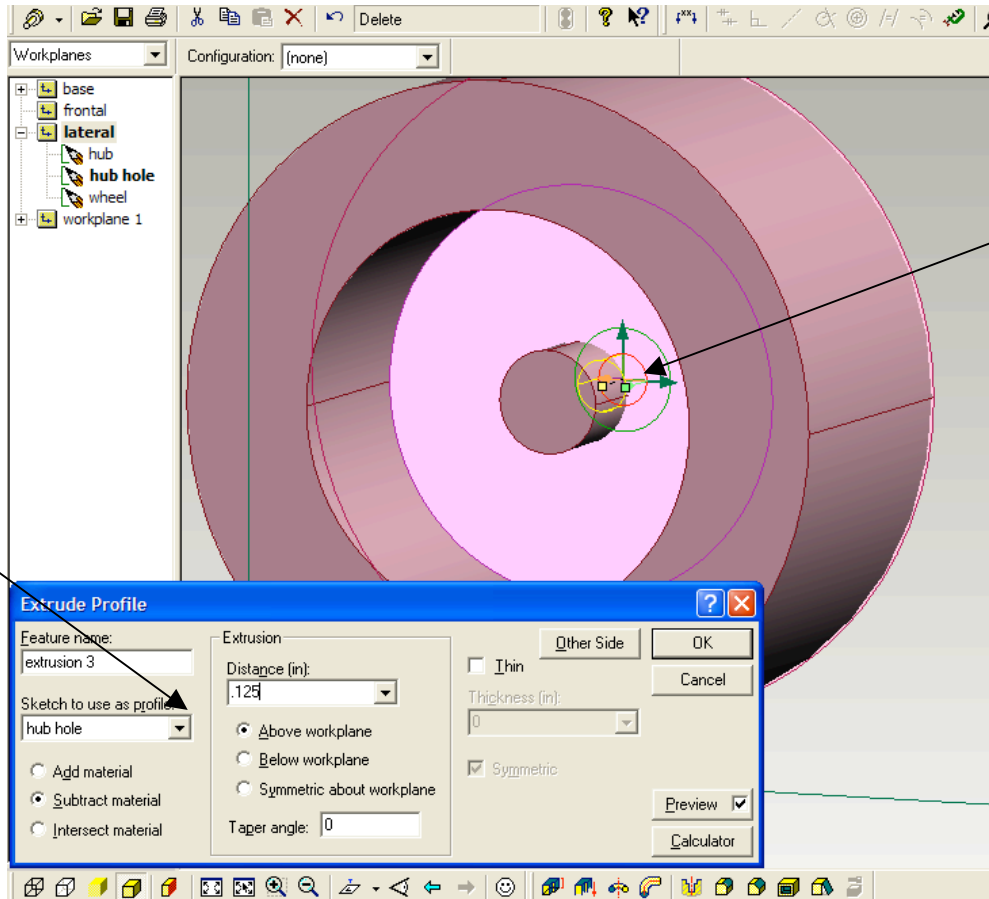

13. **Extrude** the **.125** diameter circle above the workplane; **subtract material**, a **distance of .125 inches**. (See image above.)

14. Turn the wheel around to see the hole in the back, this is what it should look like:

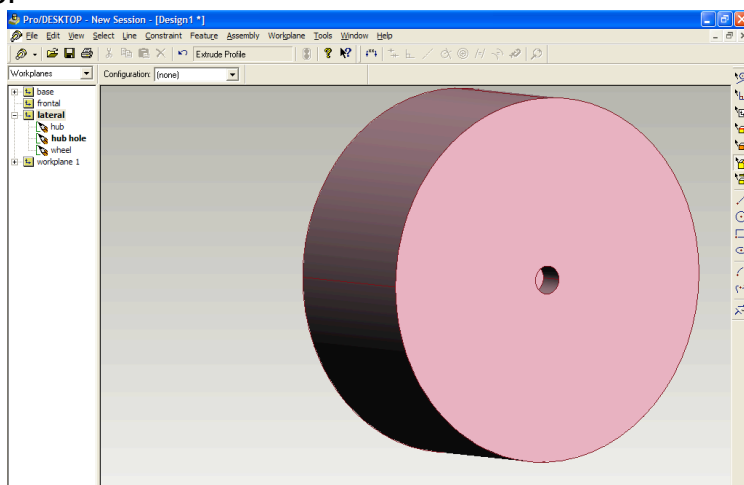

15. Use the **Round Edges** command to put a 1/16 inch round on the outside edge of the wheel. When your done save the file and call it the **Rear Wheel**.

*If you run into any problems! This is what the workplane “tree” should look like when it has been expanded.

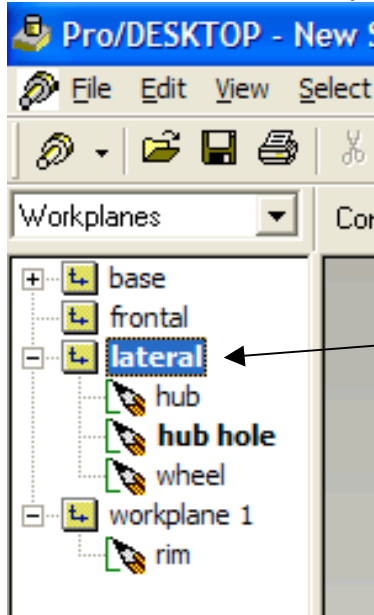

You should have these three sketches in the **lateral workplane**, and the rim drawn in the **workplane 1** (the one we created). Your “tree” should also look like this.